

The Old Apple Store—Thermal Bridging

If the thermal bridge coefficient (which is an indicator of the extra heat losses of a thermal bridge) is lower than 0.01 W/mK , the detail is said to be “Thermal Bridge Free”. If this criterion of avoiding thermal bridges is fulfilled throughout the thermal envelope, neither the designer nor the builder has to worry about cold and humid parts in the construction - and it will be far much simpler to calculate the heat energy balance. The design at Stawell was carefully worked up to limit thermal bridging to a minimum. The coefficient here is expected to be under 0.03 W/mK .

Geometric thermal bridges

The design of the 4 bed units led to complications as the rear walls slope out and the flat roof has a 15° slope. These angles meant that junctions between floors, walls and roof were significantly more complicated. It also meant that steels had to be used as opposed to the preferred glulam beams. The detailing of junctions was occasionally more complicated in reality than represented in the drawings and had to be carefully resolved on-site. This resulted in inevitable time and cost implications.



Where the wall was broken by a door or full height window at ground floor level Ecos also faced the challenge of ensuring the floor insulation accurately followed the buildings footprint to avoid cold spots.

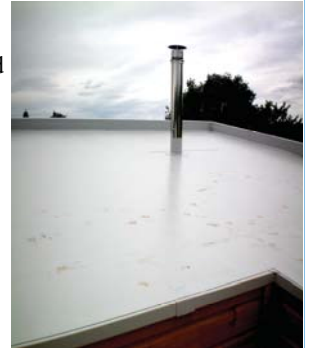
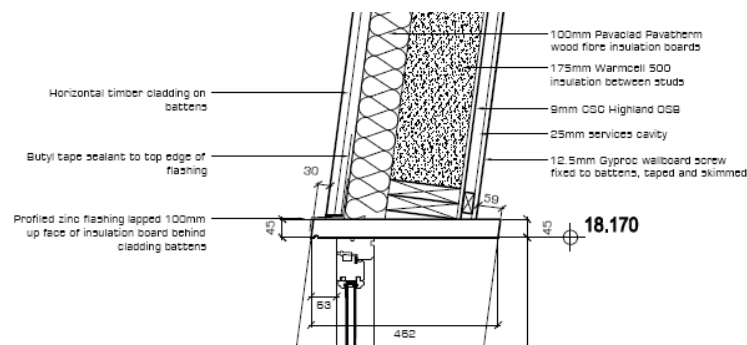

Repeating thermal bridges

The fabric design at Stawell with glulam frame, fully filled insulated cassettes insulated externally with 100mm tongue and grooved woodfibre boards, reduces repeating thermal bridging to a minimum. Junctions with the steels were carefully detailed and extra insulation added to ensure thermal breaks.



Non-repeating thermal bridges

Balconies

Rear balcony structure to Units 4 and 5 were constructed as part of the frame and supported off the ground with Glulam posts, attached to the stud, with fixings penetrating the minimum amount of the buildings insulation envelope and encased in insulation to restrict thermal bridging to a minimum

Rules to assist in the avoidance of thermal bridging

- Understand your subject
- Consider a build system or MMC with no cavity or wall ties
- Train design and construction staff.
- Create a checklist for the development that defines the most likely points and stage in the construction process for loss of thermal performance
- Ensure that contractors take ownership and responsibility for thermal design on site.